

## Portals Connect

### Product Overview

Meet Portals Connect - a private space designed to enhance, and optimize the video call experience. Users have full flexibility to personalize every aspect of their environment, including appearance on screen with adjustable spotlights and bias lighting, as well as ventilation and airflow control. An independently adjustable deluxe desk and monitor enable optimal configuration for the most ergonomic video call experience, prioritizing user comfort and confidence. Portals Connect offers plug-and-play functionality with integrated power, charging and screen-bracket for your own tech. Available in a wide range of exterior and interior finishes, it also features step-free access to support greater accessibility.

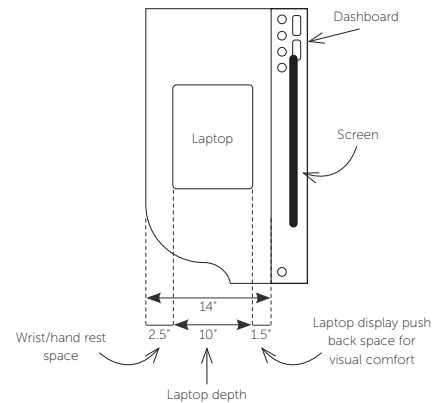

### Dimensions

47 1/4" w x 71" d x 88" / 94" h (inches)

Table Height Range: 24"-46"

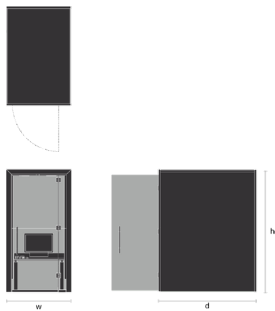

### General Drawing

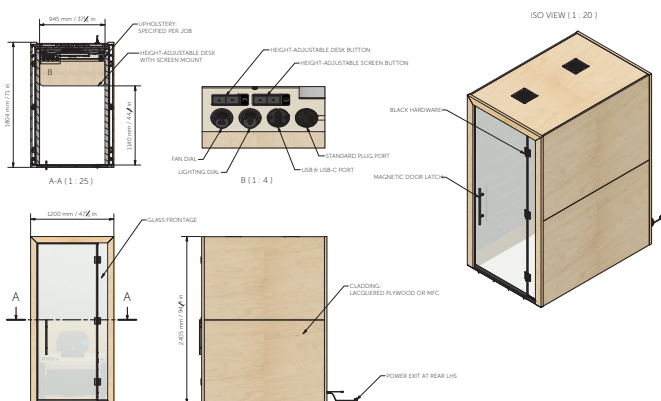

### Desk & Screen Drawings

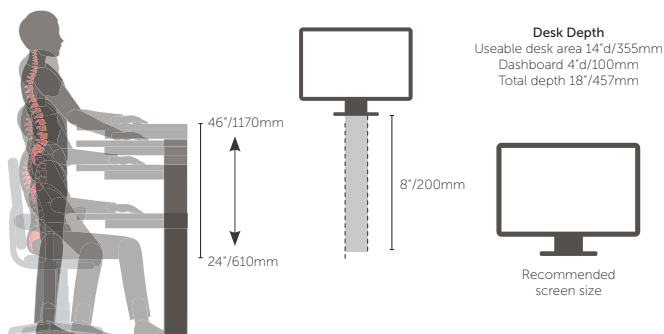

### Environmental Summary

During the development journey we always kept our environmental impact in mind. This is demonstrated in the following key features of the design when the pod is purchased with the recommended finishes:

- All materials used are LBC 3.1 Red List Compliant, an extremely stringent standard
- Patented PVC-free acoustic door seal
- Product lifecycle – the products are designed to be modular and reconfigurable to cater for future needs without wastage and using more resources.
- Power usage – the products are designed with minimum idle power usage, with a PIR movement sensor to switch off the lighting after a period of non-use.
- FSC certified lumber.

### Environmental Document & Declare Label



### Electrics

#### Lighting & Power

Low Voltage LED Lighting for consistent illumination is supplied on a PIR system with movement sensor.

- Spotlights included as standard
- Power module included as standard
- Plug-and-play, one standard 13A socket needed
- 2 year warranty on electrical parts
- Diffuse lighting behind monitor with dimmer for user adjustment for best lighting level

#### Ventilation

User adjustable ventilation. Ceiling mounted fan ventilates unit with ambient building air.



## Portals Connect

---

### Structural

Adjustable levellers on the product have up to 13/16" / 20mm tolerance.

### Seismic

To address the need for any required seismic regulations, this product can be fitted with brackets, managed per project with the Project Manager.

### Acoustics

---

#### Rating

The acoustic performance was optimised during the design process to achieve speech intelligibility privacy by using high acoustic performance materials.

'Acoustic performance' of a pod is the noise reduction level (sound from inside to outside/outside to inside). Noise reduction level is affected by external factors - e.g. the environment, external noise level, how close the pod is to a wall etc.

The materials used in the products have noise absorbing properties ranging from 30 to 60+ db rating but this is not representative of the product as a whole.

We have designed our products in such a way to block sound transfer but there are other factors such as the building sub-floor etc. that affect the noise reduction level.

### Shipping

---

Shipping dims/weight/packaging are dependant per project - please enquire.